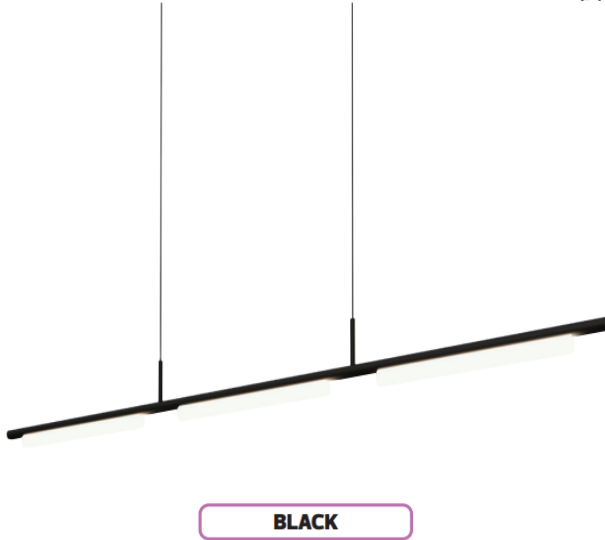

# LED SUSPENSION LIGHT

Product&amp;Family Code: 019 077 0024

**EDMOND-24**

**BLACK**

## Technical Data

Voltage (V)	175-265V
Product Wattage (W)	24
Equivalence with incandescent lamp(W)	192
Colour Render Index (Ra)	>Ra80
Colour Temperature (K)	4000K
Materials	Aluminium + Silicon
Protection Class	I
Dimmable	No
EEL	-
Warm-up time up to 60 %of the full light output	Instant Full Light
Luminous Flux (lm)	1440
Luminous Efficacy (lm/W)	60
Rated Life (hrs) ⌚	30.000
IP Rating	20
Power Factor	>0.5
Beam Angle	180°

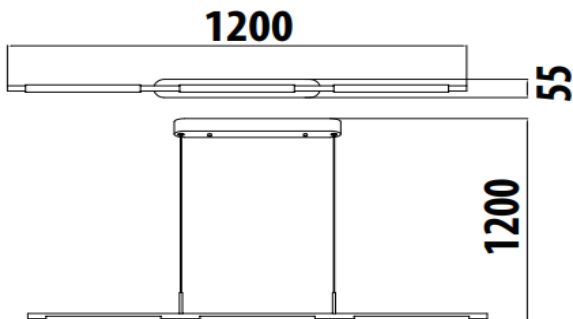
## Technical Drawing



## Applications

- LED Suspension Light has been specifically designed for use indoors and is ideal for both hospitality and residential lighting.



## Features

- High Lumen and CRI, Good quality & Constant Current driver.
- High heat dissipation, low carbon and environmental protection.
- SMD LED Lamp Base
- Very low energy consumption

