

# LED SUSPENSION LIGHT

Product&Family Code: 019 079 0100

MONARCH-100 3CCT



BLACK



## Technical Data

Voltage (V)	160-265
Product Wattage (W)	100W ; 3000K&6400K=50W, 4200K=100W
Equivalence with incandescent lamp(W)	800
Colour Render Index (Ra)	>Ra80
Colour Temperature (K)	3CCT
Materials	Aluminium + Iron + Silicon
Protection Class	I
Dimmable	Yes
EEL	-
Warm-up time up to 60 %of the full light output	Instant Full Light
Luminous Flux (lm)	7000
Luminous Efficacy (lm/W)	70
Rated Life (hrs) ⌚	30.000
IP Rating	20
Power Factor	>0.5
Beam Angle	180°

## CCT ADJUSTABLE



## Technical Drawing

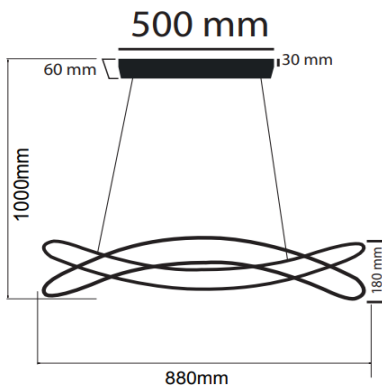

## Applications

- LED Suspension Light has been specifically designed for use indoors and is ideal for both hospitality and residential lighting.



## Features

- High Lumen and CRI, Good quality & Constant Current driver.
- High heat dissipation, low carbon and environmental protection.
- SMD LED Lamp Base
- Very low energy consumption

